

ALL DIMENSIONS IN MILLIMETERS

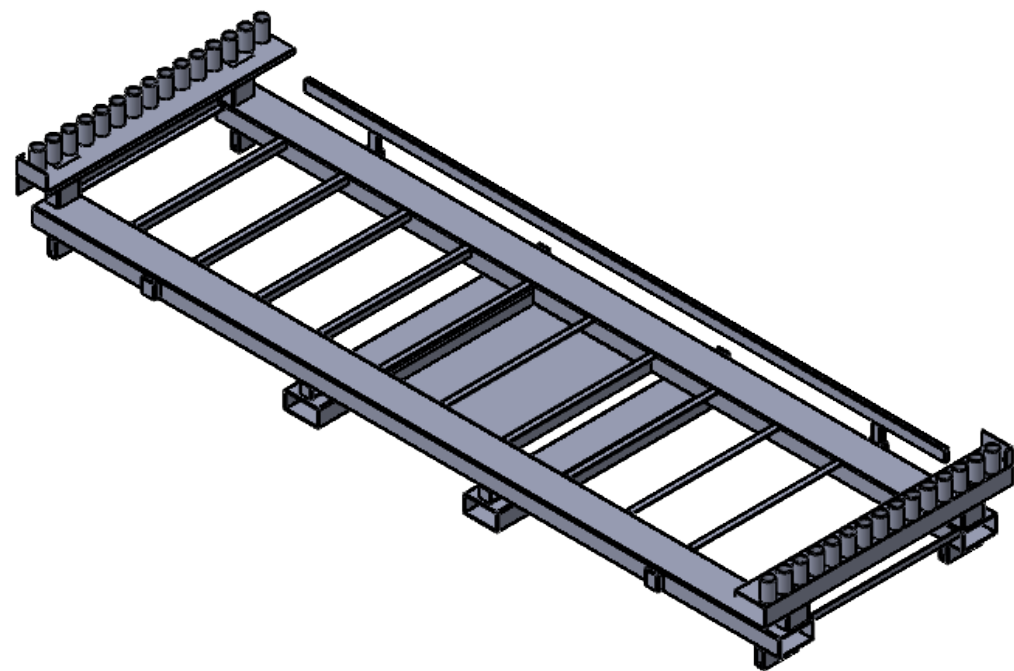
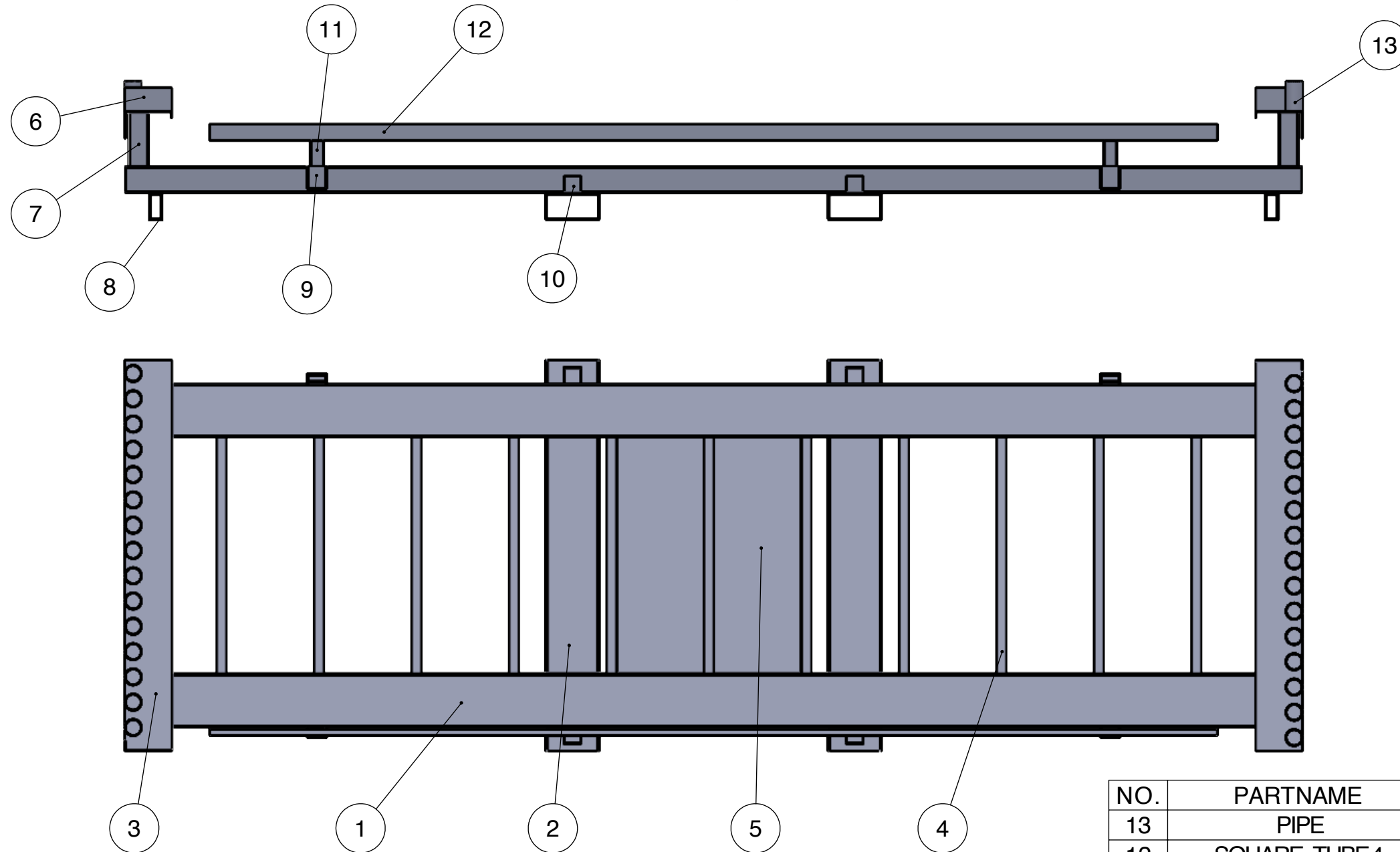

NO.	PARTNAME	MATERIAL	QTY.
13	PIPE	SHEET14 OF 14	30
12	SQUARE TUBE4	SHEET3 OF 14	2
11	SQUARE TUBE3	SHEET3 OF 14	4
10	"L" PLATE 2	SHEET13 OF 14	4
9	CLOSING TUBE	SHEET12 OF 14	84
8	SQUARE TUBE2	SHEET11 OF 14	4
7	SQUARE TUBE	SHEET10 OF 14	4
6	"L" PLATE	SHEET9 OF 14	2
5	METAL SHEET	SHEET8 OF 14	1
4	ANGLE	SHEET7 OF 14	3
3	PIPES BASE	SHEET6 OF 14	2
2	BASE 2	SHEET5 OF 14	2
1	BASE 1	SHEET4 OF 14	2

TITLE: **TRANSPORT PALETTE**

NAME	SGN	DATE	WEIGHT:
DRAWN BIŃCZAK		15/09/22	
CHK'D			
FINISH: PRE GALVANISED	TOLERANCE: ±5%		



CODE: 10059.7 Revision

ALL DIMENSIONS IN MILLIMETERS

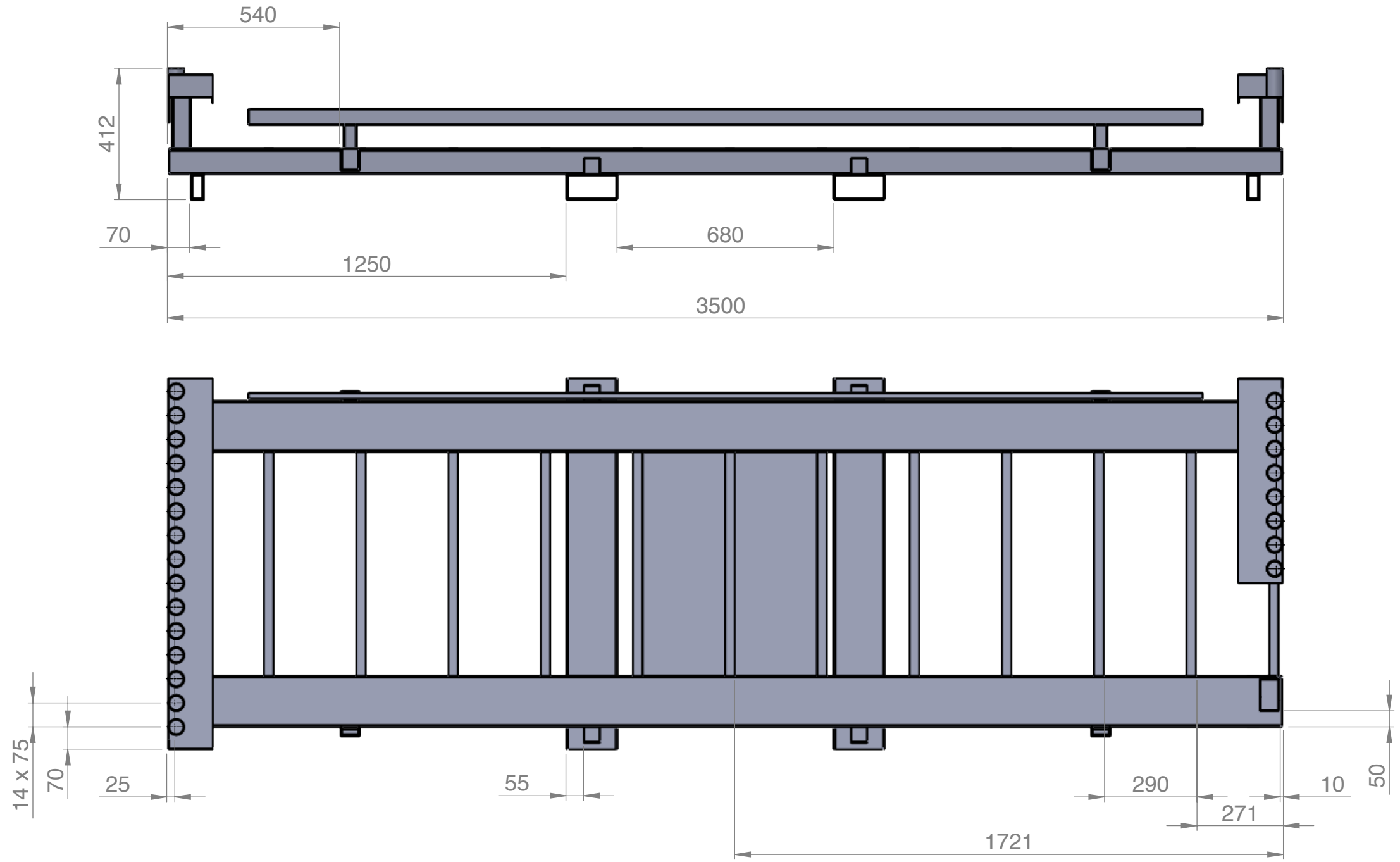
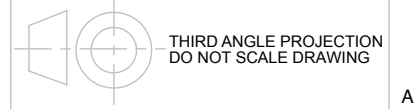

TITLE: <b>TRANSPORT PALETTE</b>				
NAME	SGN	DATE	WEIGHT:	
DRAWN BINCAK		15/09/22		
CHK'D				
FINISH: <b>PRE GALVANISED</b>			TOLERANCE: <b>±5%</b>	



CODE: 10059.7 Revision

ALL DIMENSIONS IN MILLIMETERS

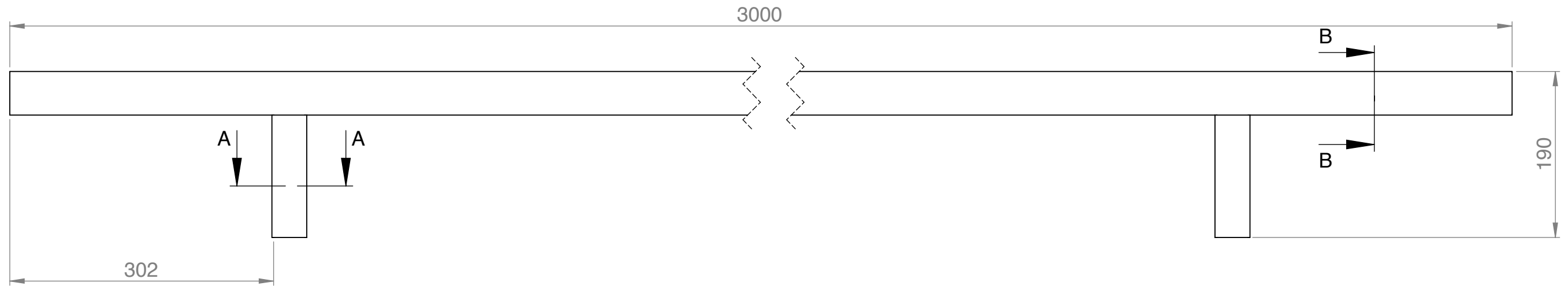
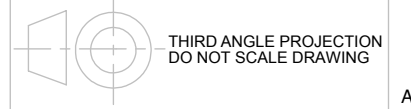

A-A  
1:1

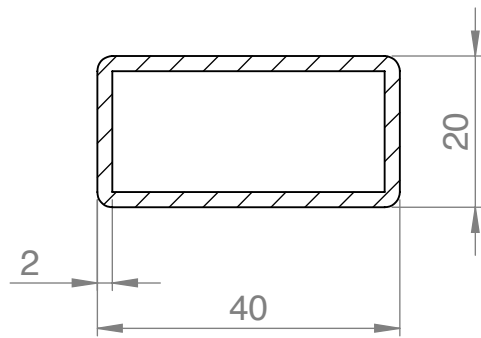

B-B  
1:1

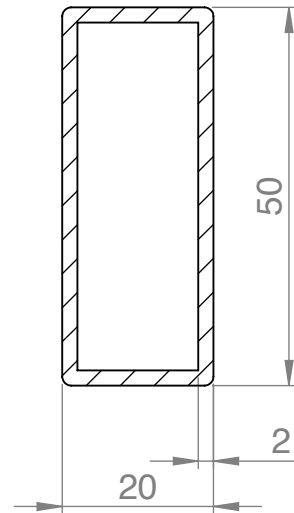

TITLE: <b>CLOSING ELEMENT</b>					
NAME	SGN	DATE	WEIGHT:		
DRAWN BINCAK		15/09/22		CODE: 10059.7	Revision
CHK'D				SCALE: 1:5	
FINISH: PRE GALVANISED			TOLERANCE: ±5%	SHEET 3 OF 14	A3

ALL DIMENSIONS IN MILLIMETERS

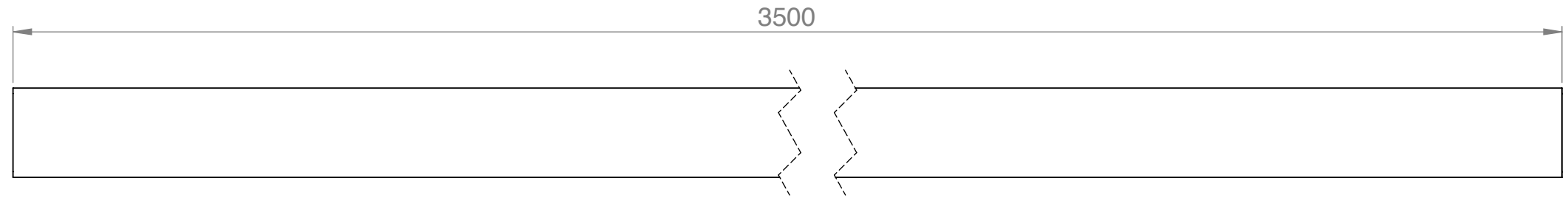
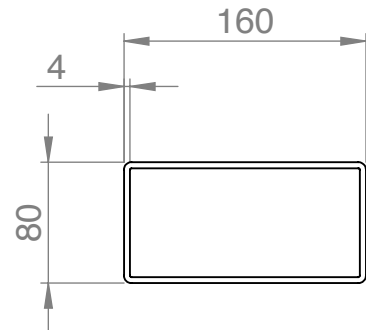

TITLE:				<b>BASE 1</b>			
DRAWN		NAME	SGN	DATE	WEIGHT:		
CHK'D		BIŃCZAK		15/09/22		CODE: 10059.7	
FINISH:		PRE GALVANISED		TOLERANCE: ±5%		Revision	
						SCALE: 1:5	SHEET 4 OF 14

ALL DIMENSIONS IN MILLIMETERS

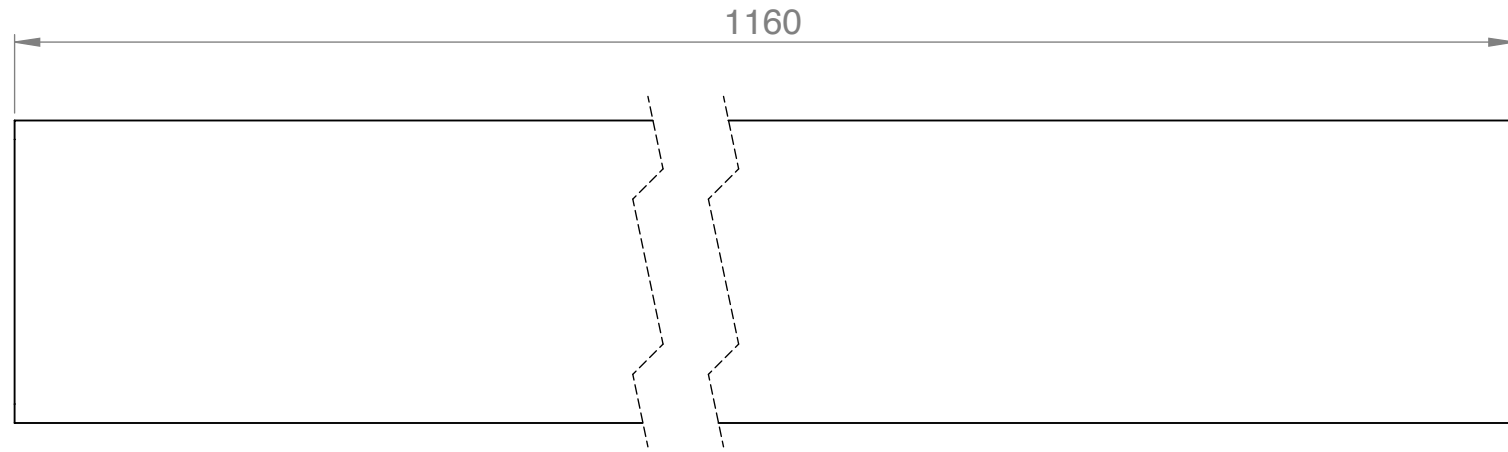
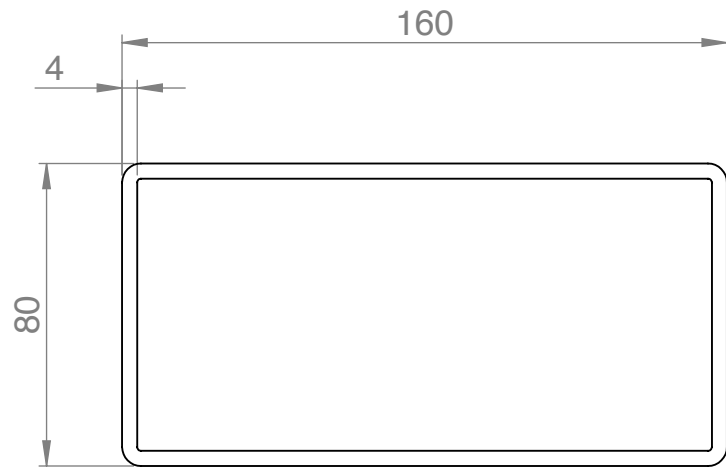
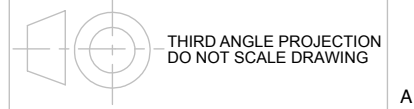

TITLE:				<b>BASE 2</b>			
DRAWN		NAME	SGN	DATE	WEIGHT:		
CHK'D				15/09/22		CODE: 10059.7	
FINISH:		PRE GALVANISED		TOLERANCE: ±5%			
						SCALE: 1:2	
						SHEET 5 OF 14	
						A3	

ALL DIMENSIONS IN MILLIMETERS

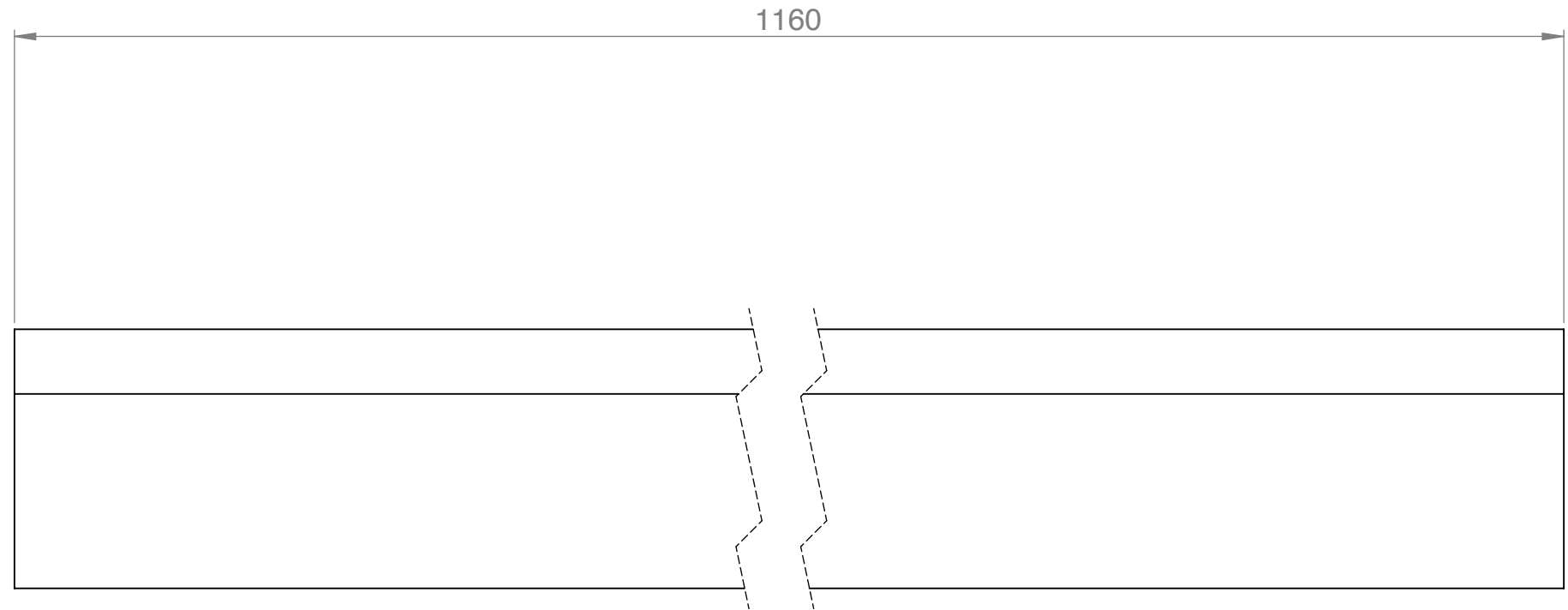
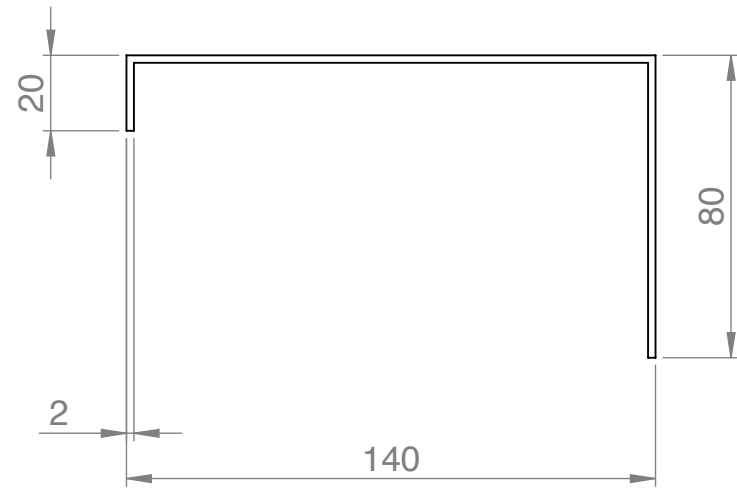

TITLE: PIPES BASE					
NAME	SGN	DATE	WEIGHT:		
DRAWN BINCZAK		15/09/22		CODE: 10059.7	Revision
CHK'D				SCALE: 1:2	
FINISH: PRE GALVANISED			TOLERANCE: ±5%	SHEET 6 OF 14	A3

ALL DIMENSIONS IN MILLIMETERS

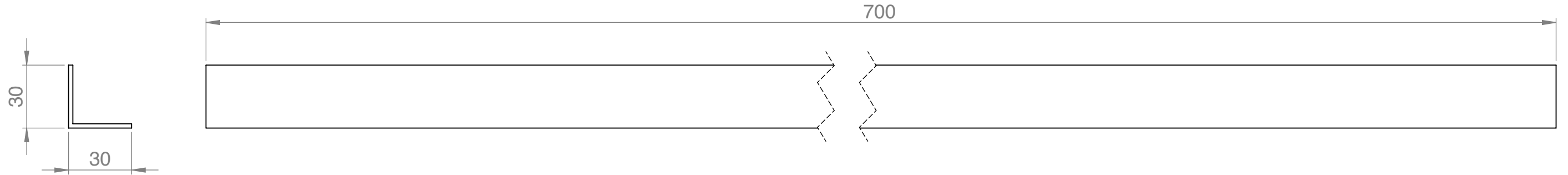
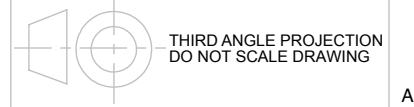

TITLE:				<b>ANGLE</b>			
NAME	SGN	DATE	WEIGHT:				
DRAWN	BINCZAK		15/09/22			CODE: 10059.7	
CHK'D						Revision	
FINISH: PRE GALVANISED			TOLERANCE: ±5%		SCALE: 1:2		SHEET 7 OF 14
						A3	

ALL DIMENSIONS IN MILLIMETERS

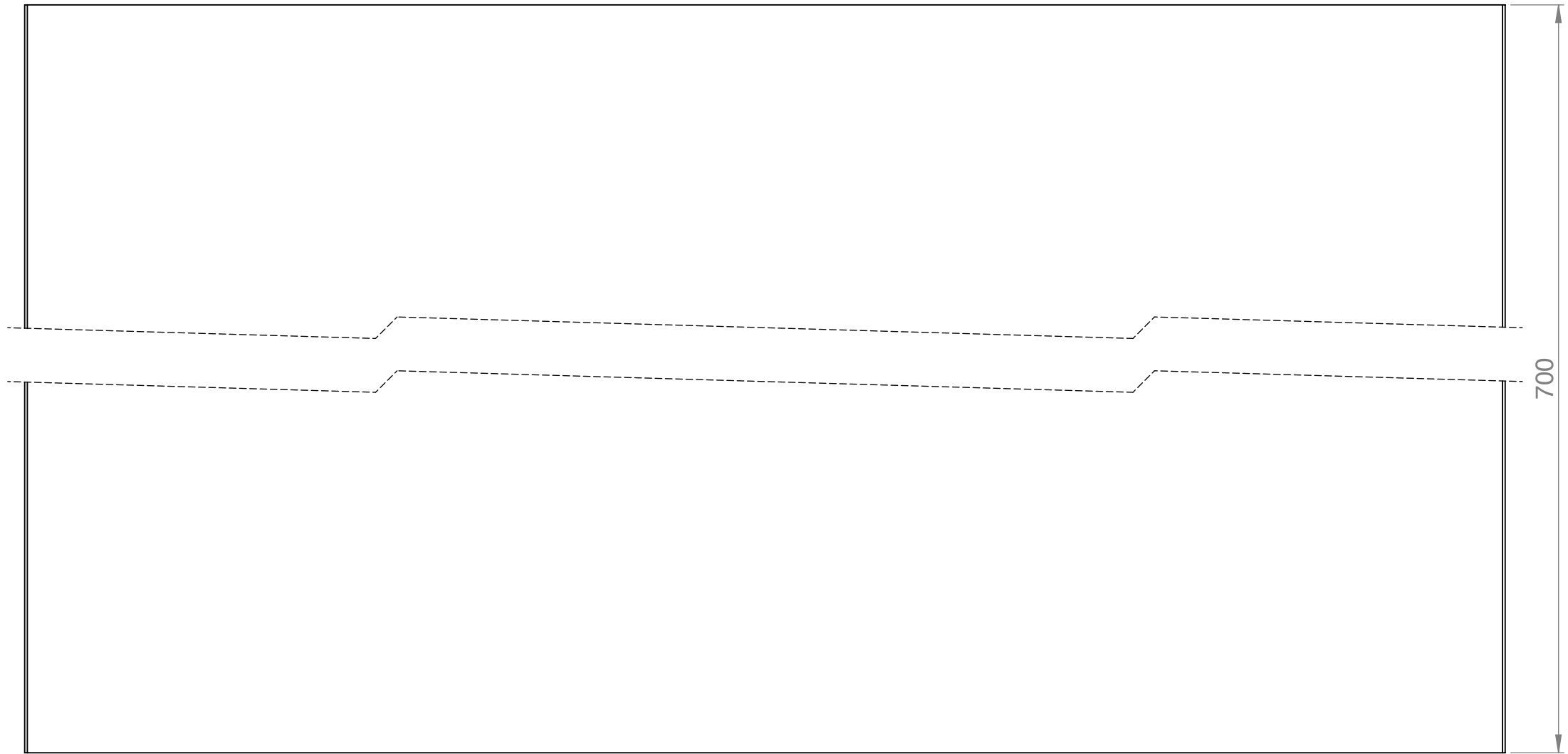
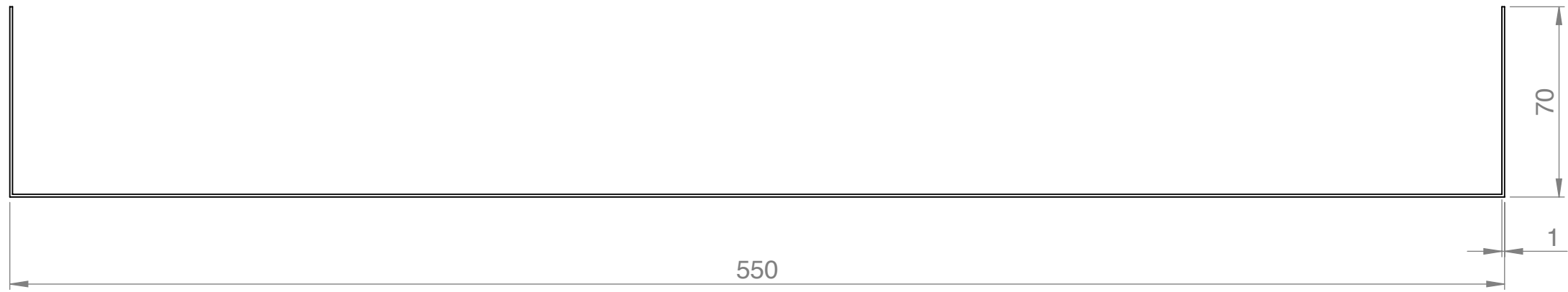

TITLE: METAL SHEET				
	NAME	SGN	DATE	WEIGHT:
DRAWN	BINCZAK		15/09/22	
CHK'D				
FINISH:	PRE GALVANISED		TOLERANCE:	±5%



CODE: 10059.7

Revision

SCALE: 1:2

SHEET 8 OF 14

A3





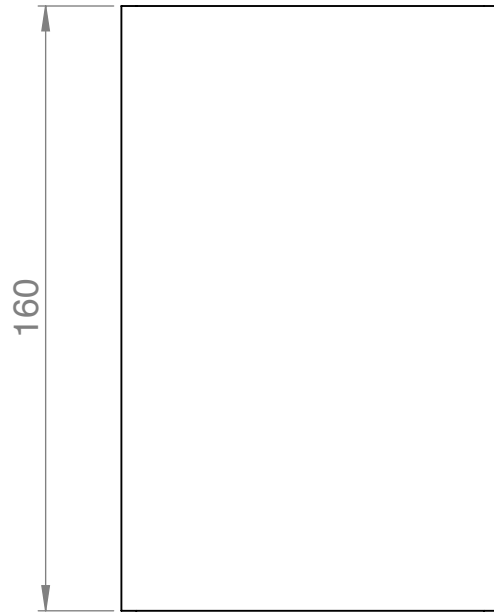
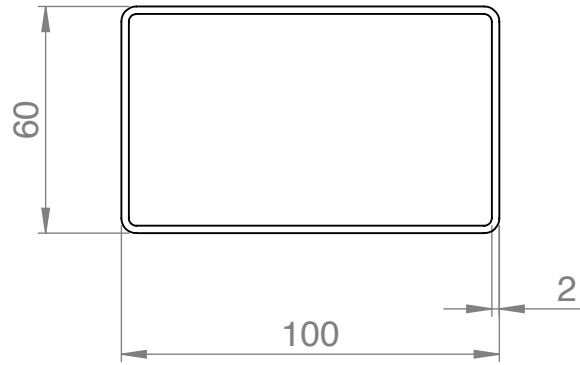

TITLE:				UNLESS IT IS PROVIDED ELSEWHERE: DIMENSIONS ARE IN MILLIMETERS			
"L" PLATE				TOLERANCE: $\pm 5\%$			
	NAME/SURNAME	SIGNATURE	DATE	FINISH:	CODE: 10059.7		A4
DRAWN	N.BINCZAK		15/09/22	PRE GALVANISED			
CHECKED							
APPROVED				WEIGHT:	SCALE: 1:1	SHEET 9 OF 14	

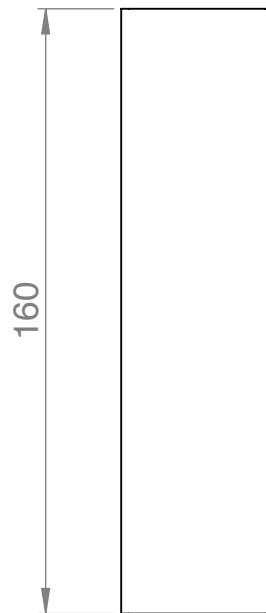
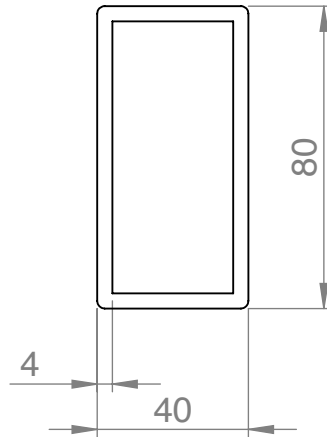

TITLE:				UNLESS IT IS PROVIDED ELSEWHERE: DIMENSIONS ARE IN MILLIMETERS			
SQUARE TUBE				TOLERANCE: $\pm 5\%$			
	NAME/SURNAME	SIGNATURE	DATE	FINISH:	CODE:	A4	
DRAWN	N.BINCZAK		15/09/22	PRE GALVANISED			
CHECKED							
APPROVED				WEIGHT:	SCALE: 1:2	SHEET 10 OF 14	



TITLE: <b>SQUARE TUBE2</b>				UNLESS IT IS PROVIDED ELSEWHERE: DIMENSIONS ARE IN MILLIMETERS			
				TOLERANCE: <b>±5%</b>			
	NAMESURNAME	SIGNATURE	DATE	FINISH: <b>PRE GALVANISED</b>	CODE: 10059.7		<b>A4</b>
DRAWN	N.BINCZAK		15/09/22				
CHECKED							
APPROVED				WEIGHT:	SCALE: 1:2	SHEET11 OF 14	

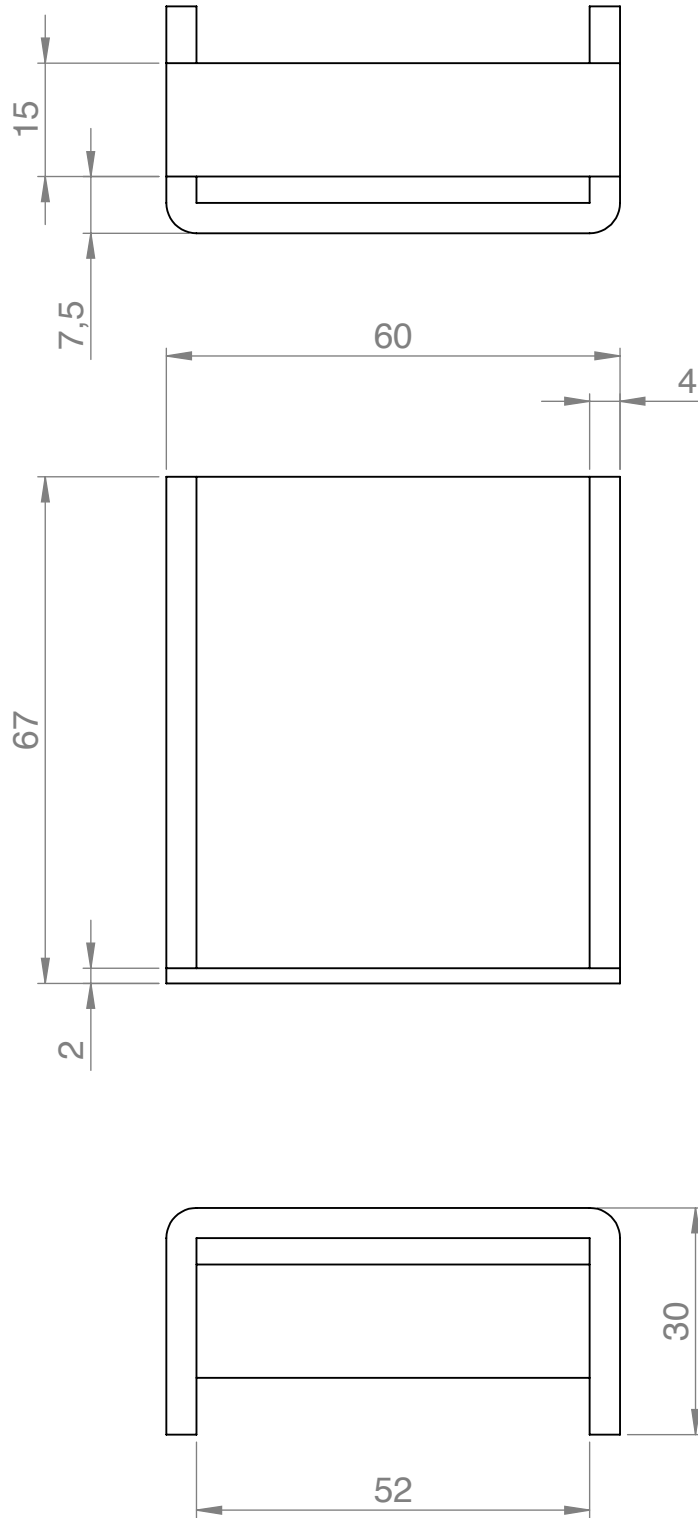

TITLE:				UNLESS IT IS PROVIDED ELSEWHERE: DIMENSIONS ARE IN MILLIMETERS			
CLOSING TUBE				TOLERANCE: ±5%			
	NAMESURNAME	SIGNATURE	DATE	FINISH:	CODE: 10059.7	A4	
DRAWN	N.BINCZAK		15/09/22	PRE GALVANISED			
CHECKED							
APPROVED				WEIGHT:	SCALE: 1:1	SHEET 12 OF 14	

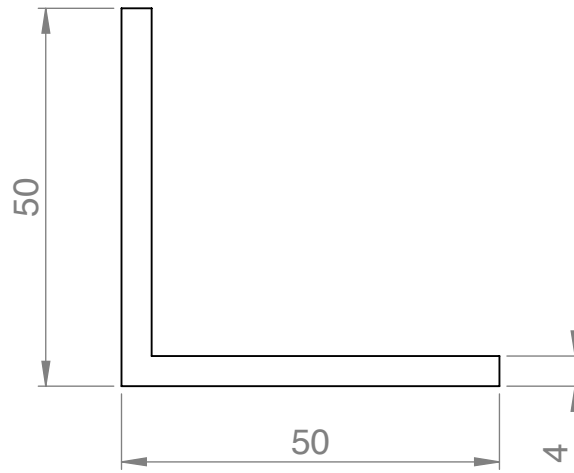

TITLE:				UNLESS IT IS PROVIDED ELSEWHERE: DIMENSIONS ARE IN MILLIMETERS			
"L" PLATE 2				TOLERANCE: $\pm 5\%$			
	NAMESURNAME	SIGNATURE	DATE	FINISH:	CODE: 10059.7	A4	
DRAWN	N.BINCZAK		15/09/22	PRE GALVANISED			
CHECKED							
APPROVED				WEIGHT:	SCALE: 1:1	SHEET 13 OF 14	

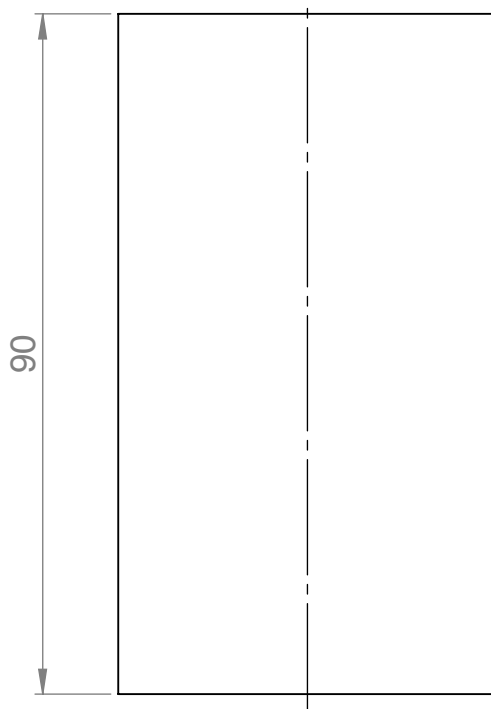
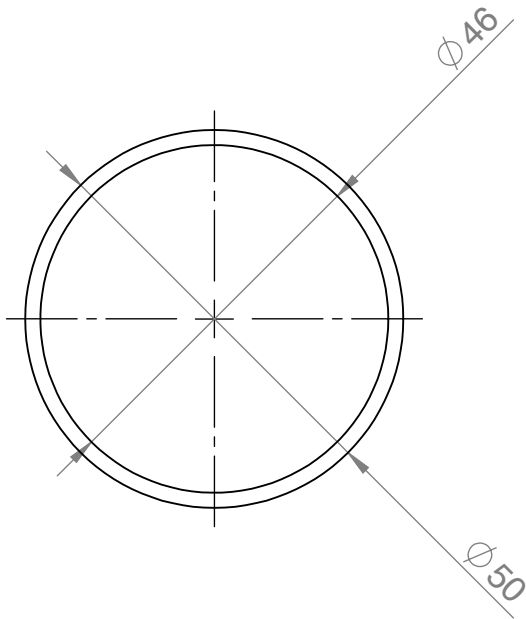

TITLE:				UNLESS IT IS PROVIDED ELSEWHERE: DIMENSIONS ARE IN MILLIMETERS			
PIPE				TOLERANCE: ±5%			
	NAMESURNAME	SIGNATURE	DATE	FINISH:	CODE: 10059.7	A4	
DRAWN	N.BINCZAK		15/09/22	PRE GALVANISED			
CHECKED							
APPROVED				WEIGHT:	SCALE: 1:1	SHEET 14 OF 14	