

ALL DIMENSIONS IN MILLIMETERS

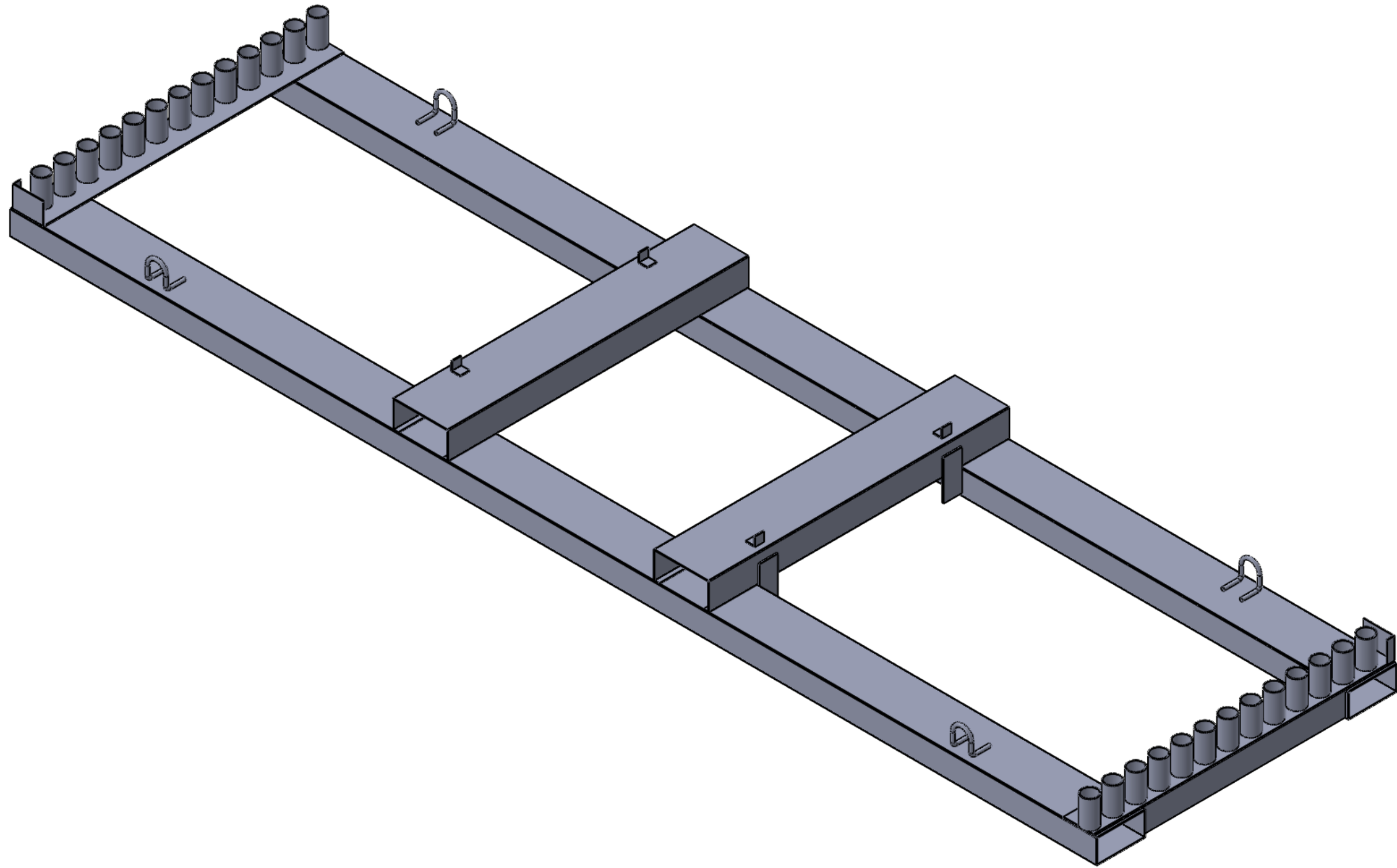

TITLE: TRANSPORT PALETTE TP				
	NAME	SGN	DATE	WEIGHT:
DRAWN	BINCZAK		08/08/23	107,5 kg
CHK'D				
FINISH:	HOT DIPPED GALVANISED		TOLERANCE:	±5%

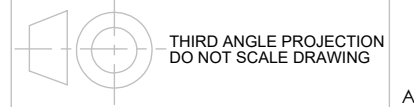

CODE: 10015.1

Revision

SCALE: 1:10

SHEET 1 OF 12

A3

ALL DIMENSIONS IN MILLIMETERS

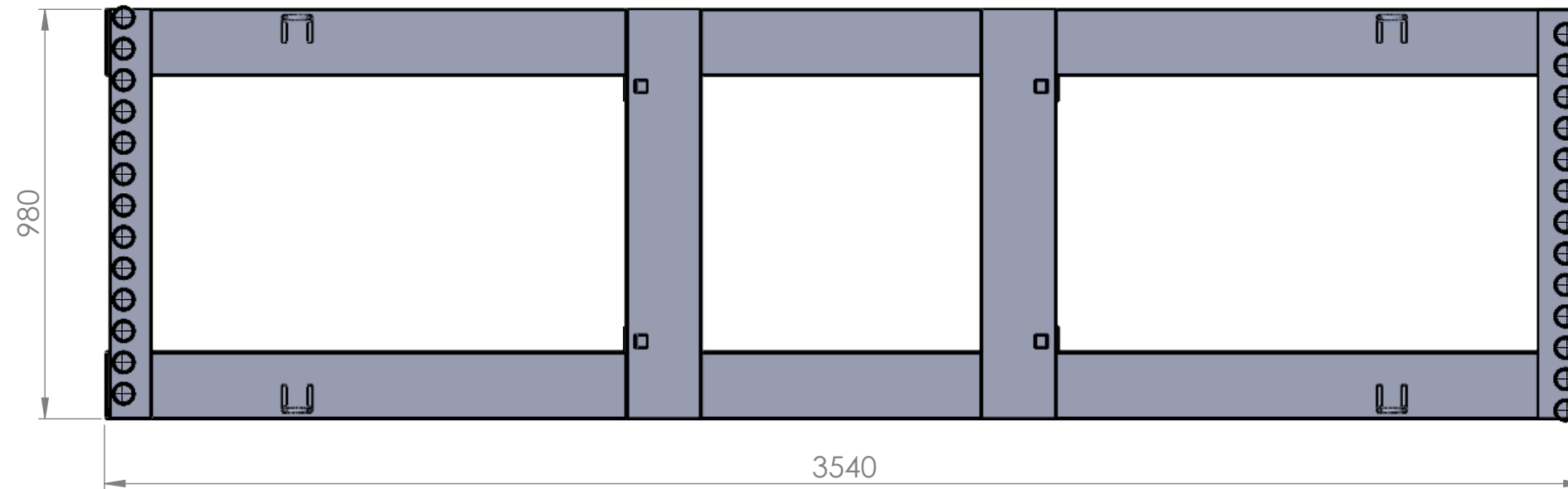
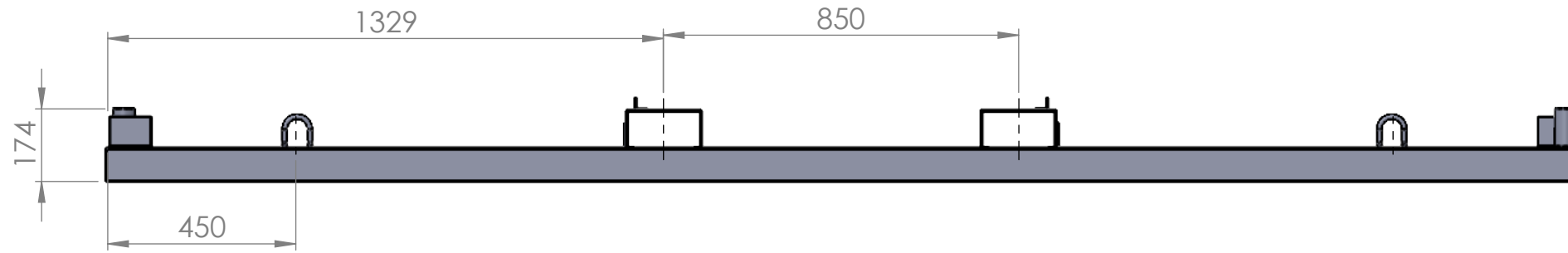
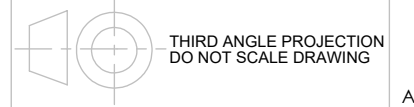

TITLE: TRANSPORT PALETTE TP				
	NAME	SGN	DATE	WEIGHT: 107,5 kg
DRAWN	BINCZAK		08/08/23	
CHK'D				
FINISH:	HOT DIPPED GALVANISED		TOLERANCE:	±5%



CODE: 10015.1

Revision

SCALE: 1:15

SHEET 2 OF 12

A3

ALL DIMENSIONS IN MILLIMETERS

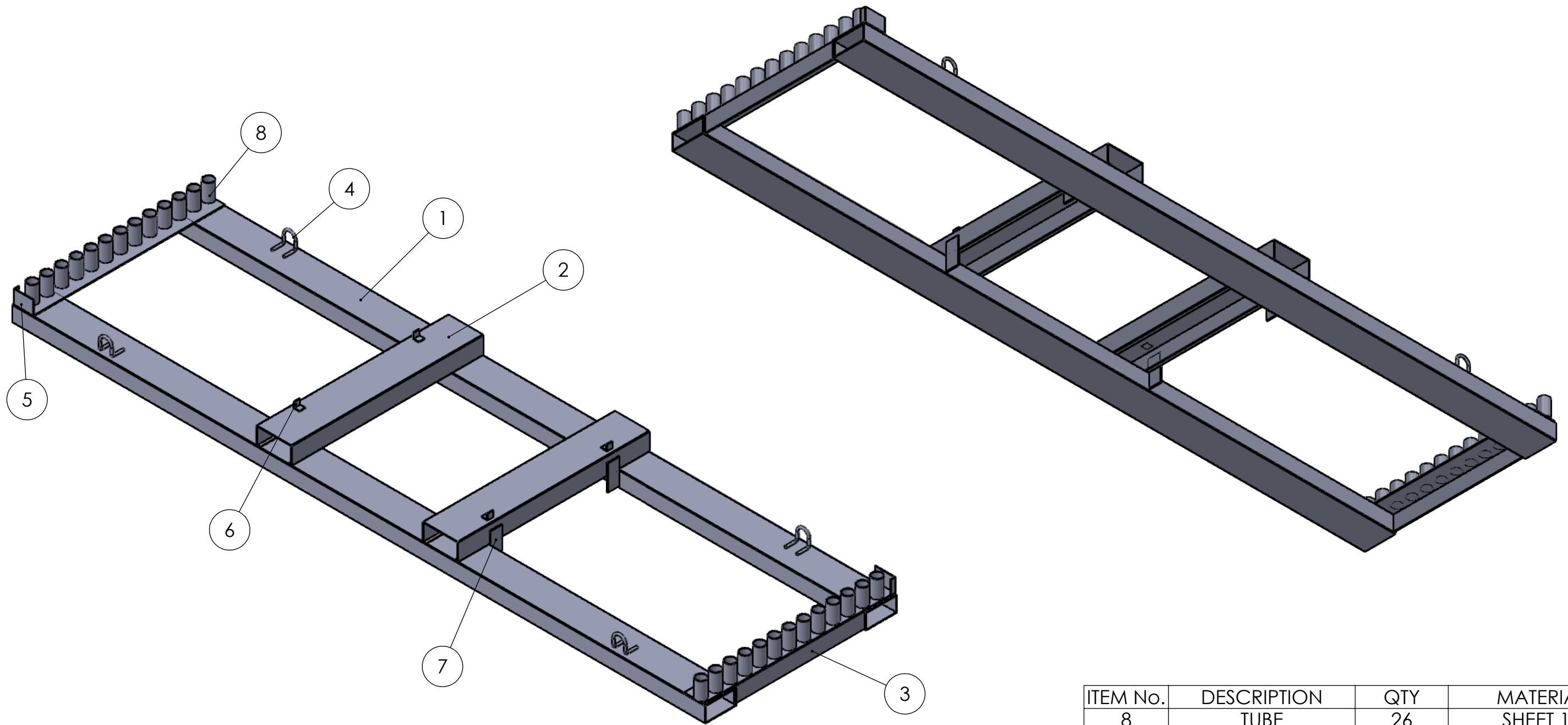
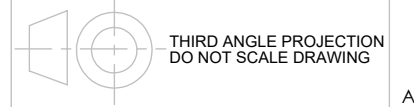

ITEM No.	DESCRIPTION	QTY	MATERIAL
8	TUBE	26	SHEET 12
7	PLATE	4	SHEET 11
6	"L" PLATE 2	4	SHEET 10
5	"L" PLATE	2	SHEET 9
4	EYE	4	SHEET 8
3	PIPES BASE	2	SHEET 7
2	BASE 2	2	SHEET 6
1	BASE	2	SHEET 5

TITLE: TRANSPORT PALETTE
TP

NAME	SGN	DATE	WEIGHT:
BINCZAK		08/08/23	107,5 kg
FINISH:	HOT DIPPED GALVANISED		TOLERANCE:
CHK'D			±5%



CODE: 10015.1 Revision

ALL DIMENSIONS IN MILLIMETERS

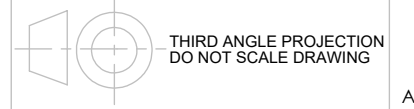

A
(1:5)



A
(1:2)

34
8

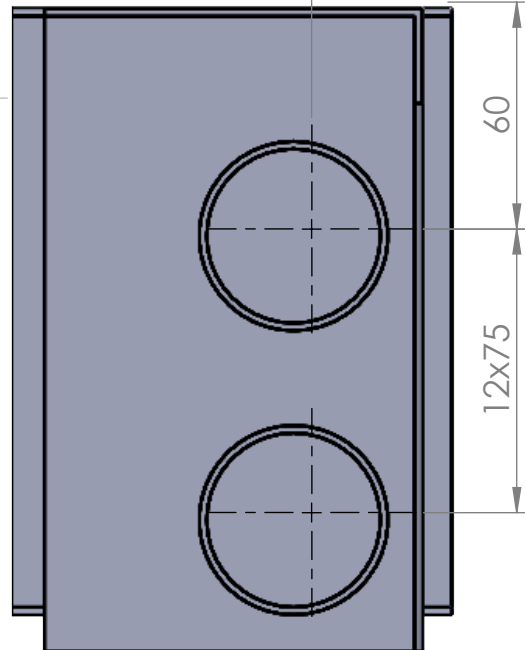

30
C-C
(1:5)

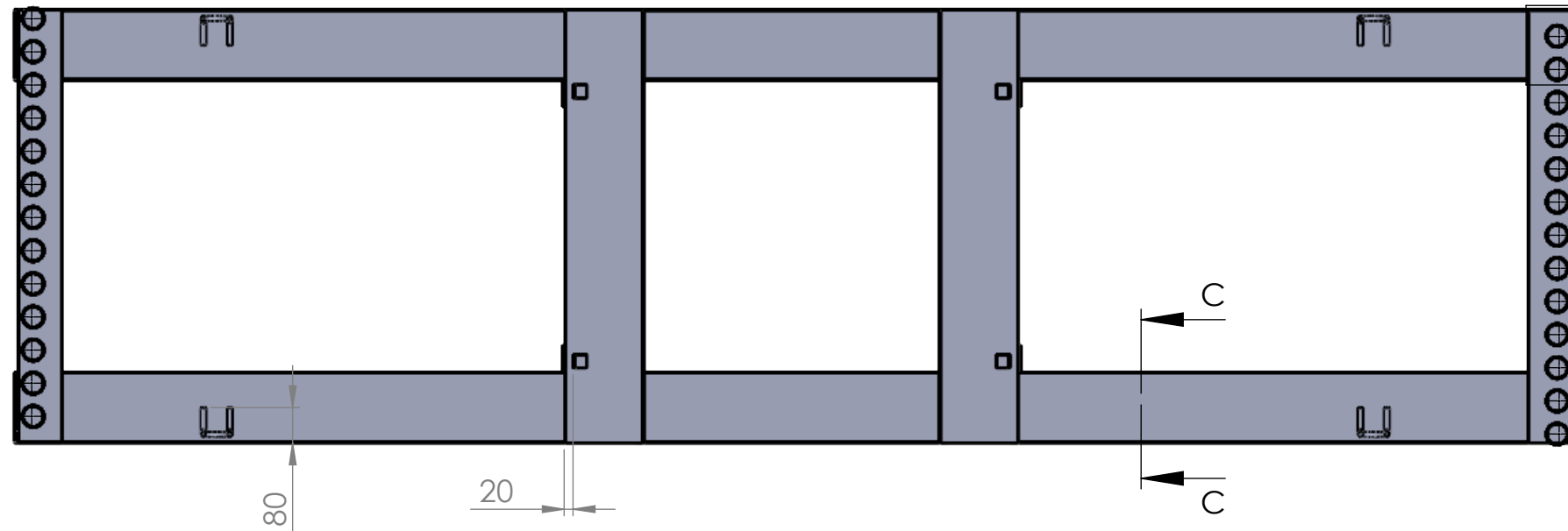
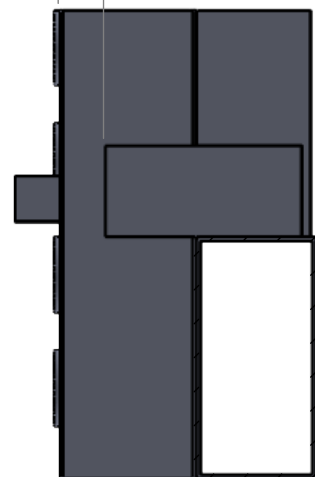

TITLE: TRANSPORT PALETTE TP				
	NAME	SGN	DATE	WEIGHT:
DRAWN	BINCZAK		08/08/23	107,5 kg
CHK'D				
FINISH:	HOT DIPPED GALVANISED		TOLERANCE:	±5%



CODE:	10015.1	Revision
-------	---------	----------

ALL DIMENSIONS IN MILLIMETERS

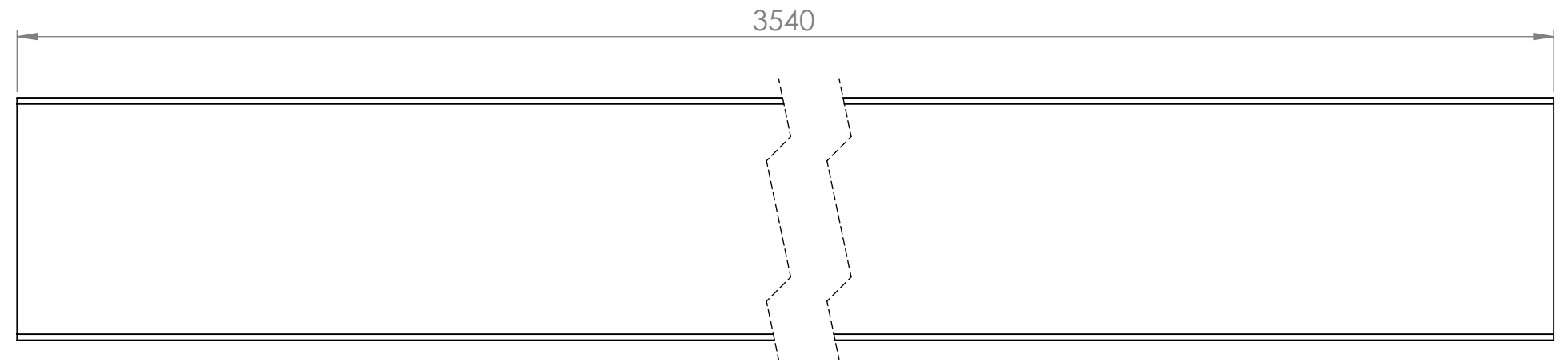
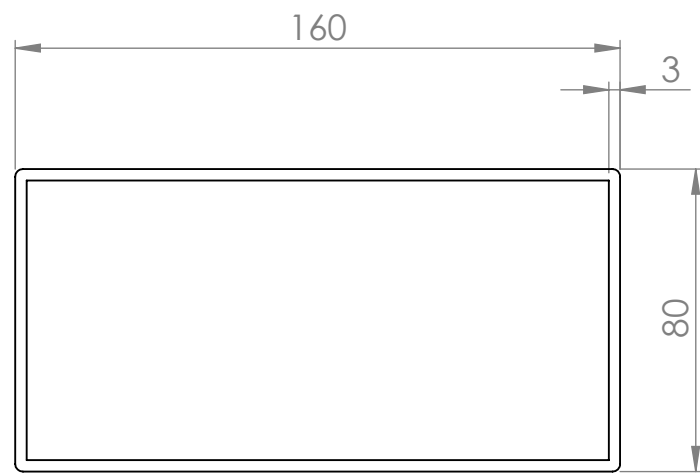
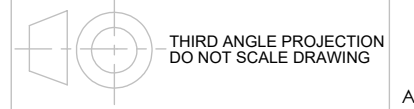

TITLE: BASE								
NAME	SGN	DATE	WEIGHT:					
DRAWN	BINCZAK		08/08/23					
CHK'D								
FINISH:	HOT DIPPED GALVANISED		TOLERANCE:	±5%		CODE:	10015.1	Revision
SCALE: 1:2						SHEET 5 OF 12		A3

ALL DIMENSIONS IN MILLIMETERS

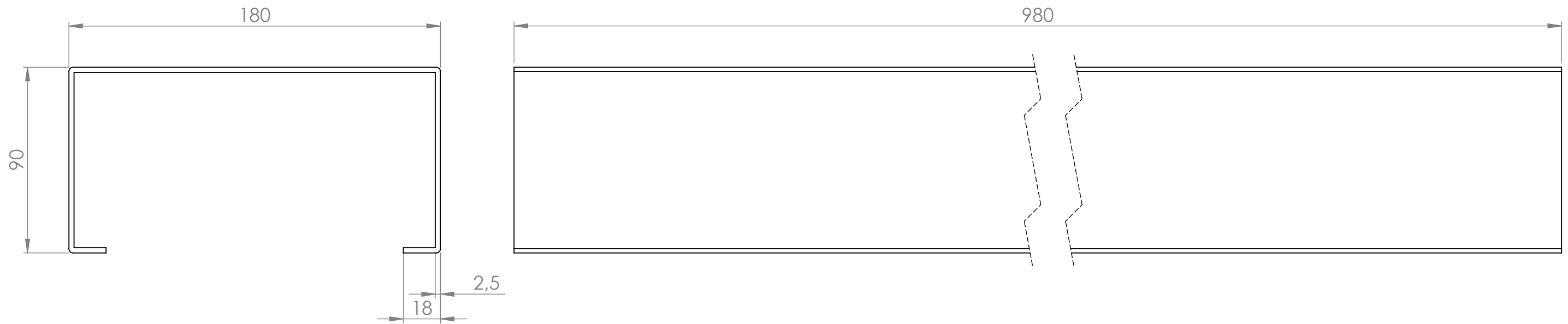
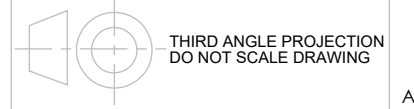

TITLE:				BASE 2			
NAME	SGN	DATE	WEIGHT:				
DRAWN	BINCZAK		08/08/23			Revision	
CHK'D							
FINISH:	HOT DIPPED GALVANISED		TOLERANCE:	±5%		CODE:	10015.1
				SCALE: 1:2	SHEET 6 OF 12		A3

ALL DIMENSIONS IN MILLIMETERS

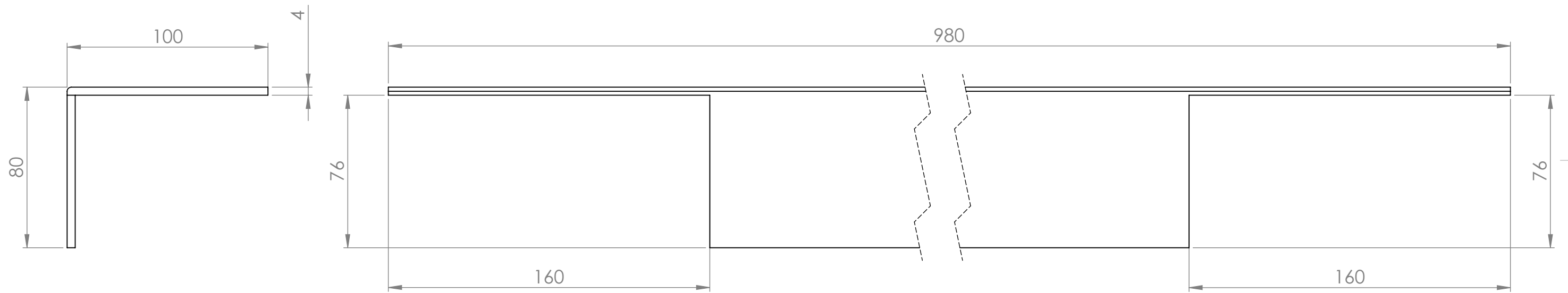
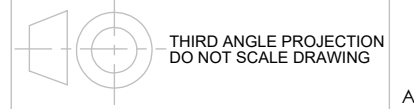

TITLE:				PIPES BASE			
NAME	SGN	DATE	WEIGHT:				
DRAWN	BINCZAK		08/08/23			CODE: 10015.1 Revision	
CHK'D							
FINISH:	HOT DIPPED GALVANISED		TOLERANCE:	±5%		SCALE: 1:2	SHEET 7 OF 12

ALL DIMENSIONS IN MILLIMETERS

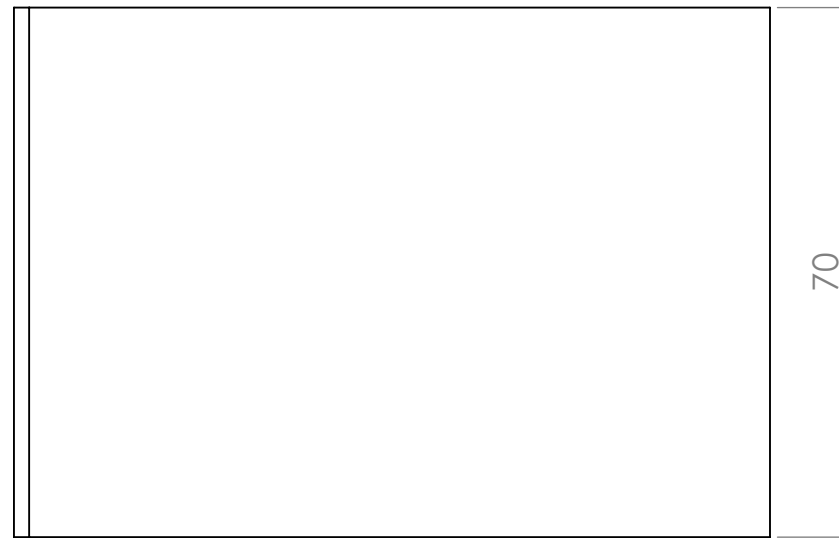
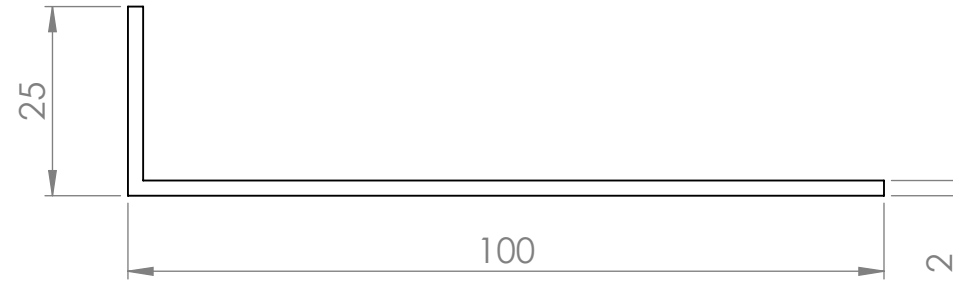
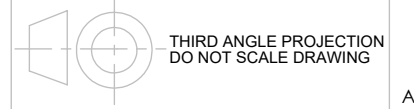

TITLE: "L" PLATE							
	NAME	SGN	DATE	WEIGHT:			
DRAWN	BINCZAK		08/08/23		CODE: 10015.1		Revision
CHK'D					SCALE: 1:1		SHEET 9 OF 12
FINISH:	HOT DIPPED GALVANISED		TOLERANCE: ±5%		A3		

ALL DIMENSIONS IN MILLIMETERS

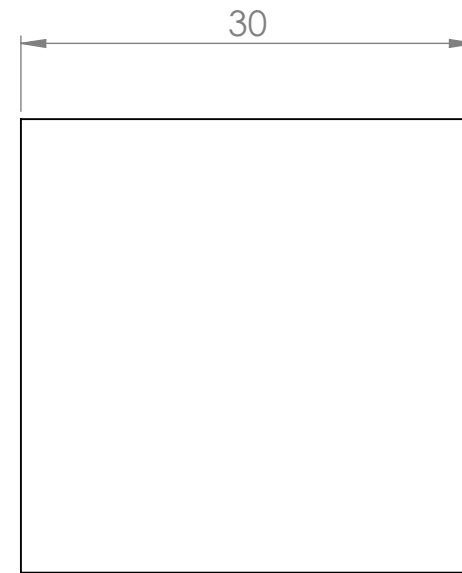
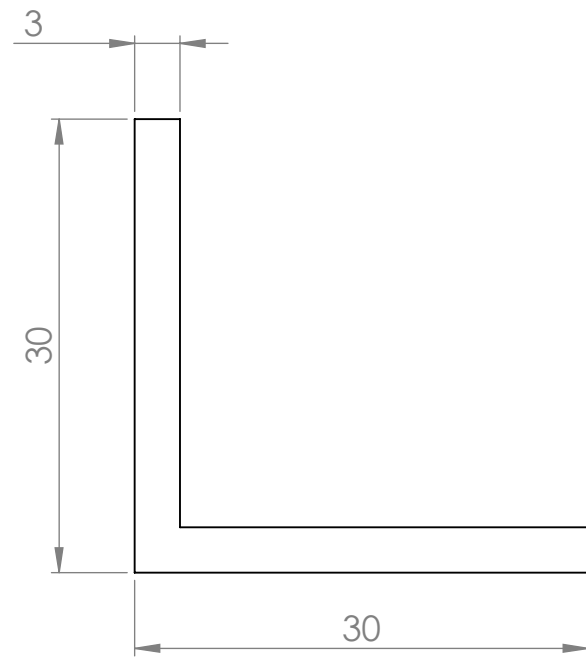
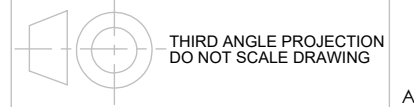

TITLE:				"L" PLATE 2					
NAME	SGN	DATE	WEIGHT:						
DRAWN	BINCZAK		08/08/23				CODE:	10015.1	Revision
CHK'D							SCALE: 2:1	SHEET 10 OF 12	A3
FINISH:	HOT DIPPED GALVANISED		TOLERANCE:	±5%					

ALL DIMENSIONS IN MILLIMETERS

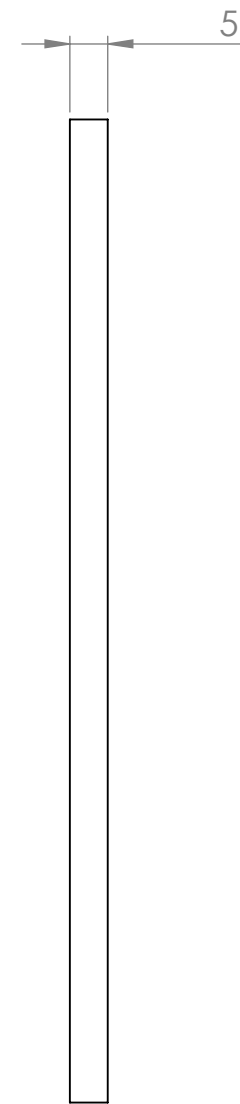
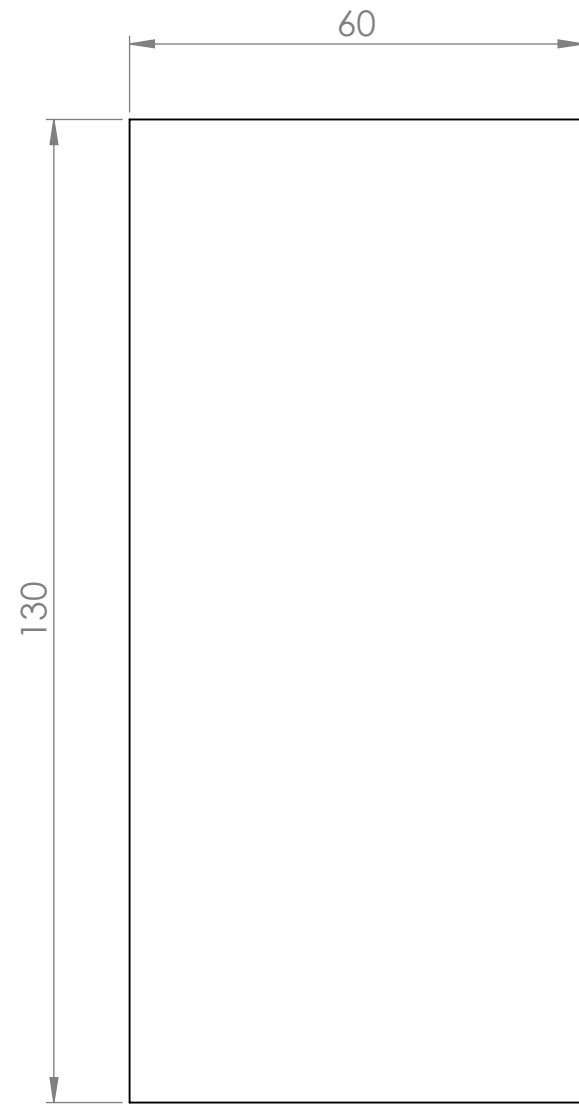
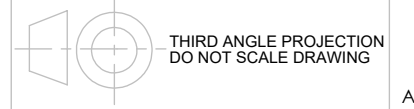

TITLE:							
PLATE							
	NAME	SGN	DATE	WEIGHT:			
DRAWN	BINCZAK		08/08/23				
CHK'D							
FINISH:	HOT DIPPED GALVANISED		TOLERANCE:	±5%			
					CODE:	10015.1	Revision
					SCALE: 1:1	SHEET 11 OF 12	A3

ALL DIMENSIONS IN MILLIMETERS

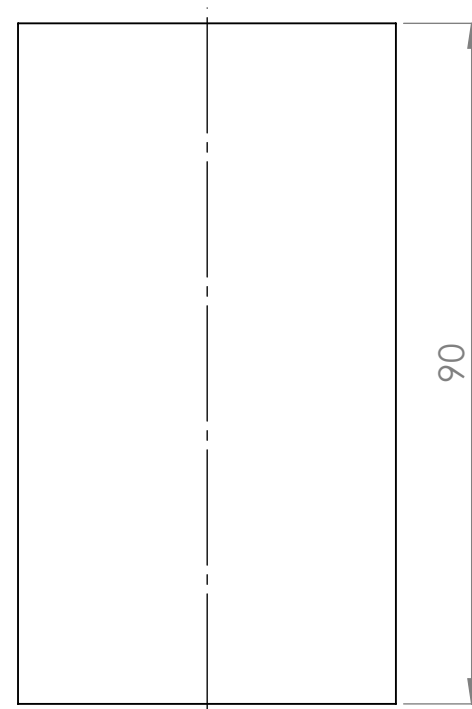
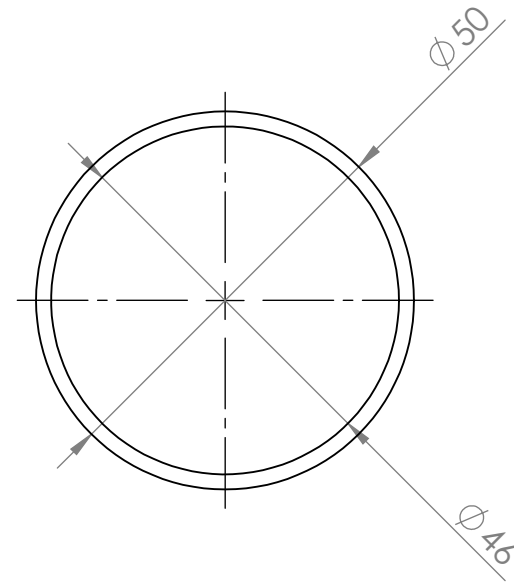
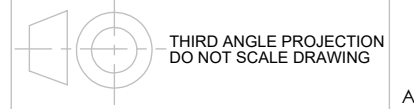

TITLE:				
TUBE				
	NAME	SGN	DATE	WEIGHT:
DRAWN	BINCZAK		08/08/23	
CHK'D				
FINISH:	HOT DIPPED GALVANISED		TOLERANCE:	$\pm 5\%$



CODE: 10015.1

Revision